

UOHC 300W Series

Industrial Power Supply

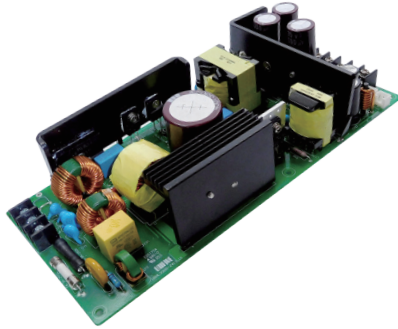

▲ UOHC3300 Series



▲ UOHC3300 Series with Chassis



■ Please contact our sales department for safety standard of each model.

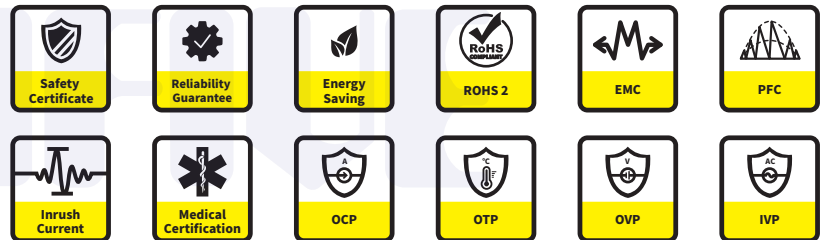

Model Name Definition

U O H C 3 3 0 0 - - - - -

① ② ③ ④ ⑤ ⑥ ⑦ ⑧ ⑨

- ① UNIFIVE Product
- ② Serial Name
- ③ Serial Name
- ④ Serial Name
- ⑤ Serial Name
- ⑥ Output Power Rating
- ⑦ Output Voltage
- ⑧ Output Current
- ⑨ Optional Items
 - N Typical Type
 - R Remote Control and Increase Output (5V, 2A)
 - S Increase Output (5V, 2A)
 - CN Typical Type with Chassis
 - CR Remote Control and Increase Output (5V, 2A) with Chassis
 - CS Increase Output (5V, 2A) with Chassis

5 years warranty

Caution! Do not twist or bend the printed circuit board since SMD components were soldered on it.

Be sure to do the necessary test for the equipment of end user which supplied power by this switching power supply and following the specifications of EMC/EMI.

Product Highlights

- Stability
- Conditional Peak Output Up to 600W
- Meet Complies with IEC61000-3-2
- Energy Efficiency
- Power Factor Correction
- Full Range Input Voltage (85Vac~264Vac)
- Inrush Current Limit
- Operating Altitude Up to 5,000m
- Add Internal Standby Power (5V) Supplied Power for Remote Control
- Appendix 8 of PSE : Comply with Dusty Requirement.

Efficiency

- up to 89%

Protection

- Short Circuit Protection
- Over Voltage Protection
- Over Current Protection
- Over Temperature Protection
- Brown In and Brown Out Protection

Safety Standard

- 60065-1
- 60335-1
- 60601-1
- 60950-1
- 61558-1
- 62368-1
- PSE 別表第八
100V 基準に準拠

Emissions

- FCC Part18 Class B
- CE CISPR 11 EN55011
- VCCI Class B
- CE CISPR 14 EN55014-1
- FCC Part15 Class B
- CE CISPR 32 EN55032
- BS EN 55032
- BS EN55011
- BS EN55014-1

*Power supply mounted in user's metal chassis

Immunity

- EN 55035
- BS EN 55035
- EN60601-1-2
- BS EN60601-1-2
- EN55014-2
- BS EN55014-2

Derating Curve of Operating Ambient

Power Supply Positioning:

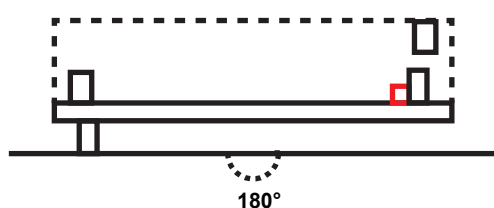

Horizontal

Derating Curve:

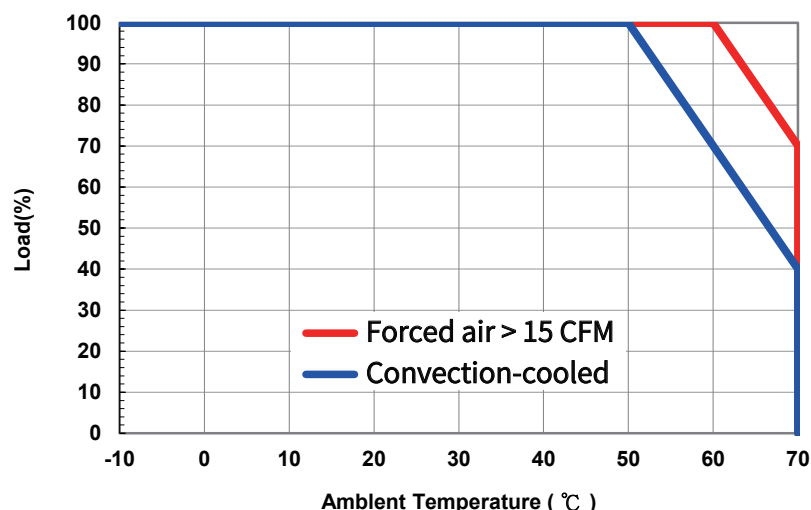

UOHC 300W Series						
Model		UOHC3300-2413				
Output		Output 1			Output 2 (Option)	
Output Wattage Max.(W)		300W (600W(*1))			10W	
DC Output	Convection	24.0V / 12.5A (25.0A(*1))	36.0V / 8.4A (16.8A(*1))	48.0V / 6.3A (12.6A(*1))	5.0V / 2.0A	
DC Output	Forced Air (*2)	24.0V / 15.0A (25.0A(*1))	36.0V / 10.0A (16.8A(*1))	48.0V / 7.5 A (12.6A(*1))	5.0V / 2.0A	
Specifications						
Input	Voltage (V)		85Vac~264Vac			
	Current (A)	ACIN 100V	4.3A Typical (Io=100%)			
		ACIN 200V	2.2A Typical (Io=100%)			
	Frequency (Hz)		50Hz/60Hz (47Hz~63Hz)			
	Efficiency (%)	ACIN 100V	87.0% Typical			
		ACIN 200V	89.0% Typical			
	Power Factor (%)	ACIN 100V	0.99 Typical			
		ACIN 200V	0.95 Typical			
Inrush Current (A)	ACIN 100V	15A/30A Typical (Full Load, Cold Start, Ta=25°C)/Restart After More than 3sec.				
	ACIN 200V	30A/30A Typical (Full Load, cold start, Ta=25°C)/Restart After More than 3sec.				
Leakage Current (mA)		0.45/0.75 Max. (ACIN 100V/200V 60Hz,Io=100%, According to IEC60950-1)				
Output	Voltage (V)		24.0V	36.0V	48.0V	5.0V
	Current (A)		12.5A	8.4A	6.3A	2.0A
	Line Regulation (mV)		96mV,Max.	144mV,Max.	192mV,Max.	40mV,Max.
	Load Regulation (mV)		150mV,Max.	240mV,Max.	240mV,Max.	40mV,Max.
	Ripple (mVp-p) (0°C to +50°C) (*3)		120mV,pk-pk	150mV,pk-pk	150mV,pk-pk	50mV,pk-pk
	Ripple (mVp-p) (-10°C to 0°C) (*3)		160mV,pk-pk	200mV,pk-pk	200mV,pk-pk	90mV,pk-pk
	Noise (mVp-p) (0°C to +50°C) (*3)		150mV,pk-pk	250mV,pk-pk	250mV,pk-pk	100mV,pk-pk
	Noise (mVp-p) (-10°C to 0°C) (*3)		180mV,pk-pk	300mV,pk-pk	300mV,pk-pk	140mV,pk-pk
	Temperature Regulation (mV)	0 to +50°C	240mV,Max.	360mV,Max.	480mV,Max.	-
		-10 to +50°C	290mV,Max.	450mV,Max.	600mV,Max.	-
	Drift (mV)(*4)		96mV,Max.	144mV,Max.	192mV,Max.	-
	Start-Up Time (ms)		650 Typical (ACIN 100V, Full Load) , at 25°C			
	Hold-Up Time (ms)		20 Typical (ACIN 100V, Full Load) , at 25°C			
	Output Voltage Setting (V)		24.0V~24.96V	36.0V~37.44V	48.0V~49.92V	4.75V~5.25V
	Output Voltage Variable Range (V)		21.6V~27.5V	32.4V~39.6V	39.6V~52.8V	-
	Over Current Protection		Over 101% of Peak Current ; Latch Off	Over 101% of Peak Current ; Latch Off	Over 101% of Peak Current ; Latch Off	3.0A Min. ; Latch Off
	Over Voltage Protection		27.6V~33.6V; Latch Off	41.4V~50.4V; Latch Off	55.2V~61.0V; Latch Off	9.5V Max; Latch Off
Short Protection		Latch Off				
Remote On/Off		Option				
Isolation	Input-Output.RC		AC4,000V 1Minute, Cutoff Current = 10mA (at Room Temperature)			
	Input-FG		AC2,000V 1Minute, Cutoff Current = 10mA (at Room Temperature)			
	Output.RC-FG		DC500V 1Minute, Cutoff Current = 25mA (at Room Temperature)			
Operating Temperature/Humidity/Altitude		-10°C~70°C / 20%RH~90%RH / 5000m Max. (Derating is Required)				
Storage Temperature/Humidity		-20°C~75°C / 20%RH~90%RH				
Vibration		10 - 55Hz, 19.6m/s ² (2G), 3Minutes Period, 60Minutes Each along X, Y and Z Axis				
Impact		JIS-C-0041 Half Sin Wave, 300 m/s ² , X, Y, Z, 6ms, 3 Times for Each Direction. (196.1m/s ² (20G), 11ms, Once Each X, Y and Z Axis)				
Safety		UL 60950, EN 60950, UL 62368, EN 62368				
EMC		meet VCCI Class B, FCC Class B, CISPR 32 Class B, EN55032				
Harmonic Attenuator		Meet IEC61000-3-2				
Size		no Chassis:222(L)*95(W)*52(H)mm with Chassis:252(L)X108(W)X66(H)mm				
Cooling Method		Convection/Forced Air				
<ul style="list-style-type: none"> 1. Power supply can be operated in condition of peak load 600W for 10 seconds and the duty is less than 0.5. Average current must equals to or less than 12.5A. 2. Condition for forced air is no less than 15CFM. 3. Parallel a 22uF Aluminum electrolytic capacitor and 0.1uF ceramics capacitor at the test point. The position of test point is 150mm from output terminal to system load. The bandwidth of oscilloscope is 20MHz. 4. Drift is the change in DC output for an eight hour period after a half-hour warm-up at 25C,with the input voltage held constant at the rated input/output. 						

UOHC3300-2413

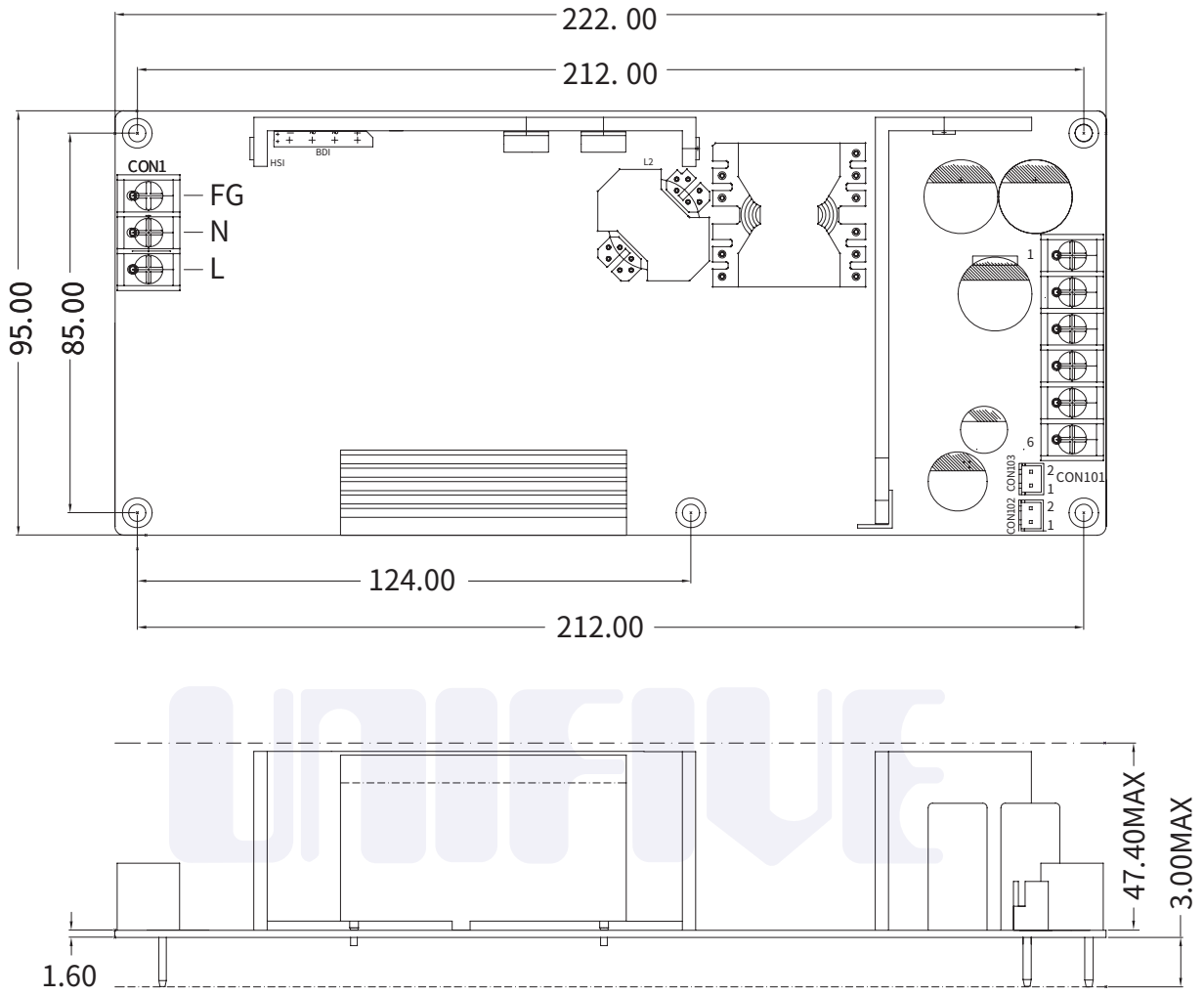

Mounting Holes : 5-Ø3.50

TOLERANCE: ±0.5
Unit:mm

CON1

PIN NUMBER	INPUT
1	AC(L)
2	AC(N)
3	FG
CON1 : INPUT CONNECT	

CON102

PIN NUMBER	REMOTE
1	RC(+)
2	RC(-)
CON102: REMOTE CONNECT MODEL : B2B-XH-A (THE EQUIVALENT)	

CON103

PIN NUMBER	OUTPUT
1	5V(+)
2	5V(-)
CON103: OUTPUT CONNECT MODEL : B2B-XH-A (THE EQUIVALENT)	

CON101

PIN NUMBER	OUTPUT
1-3	-V
4-6	+V
CON101: OUTPUT CONNECT	

UOHC3300-2413-C_

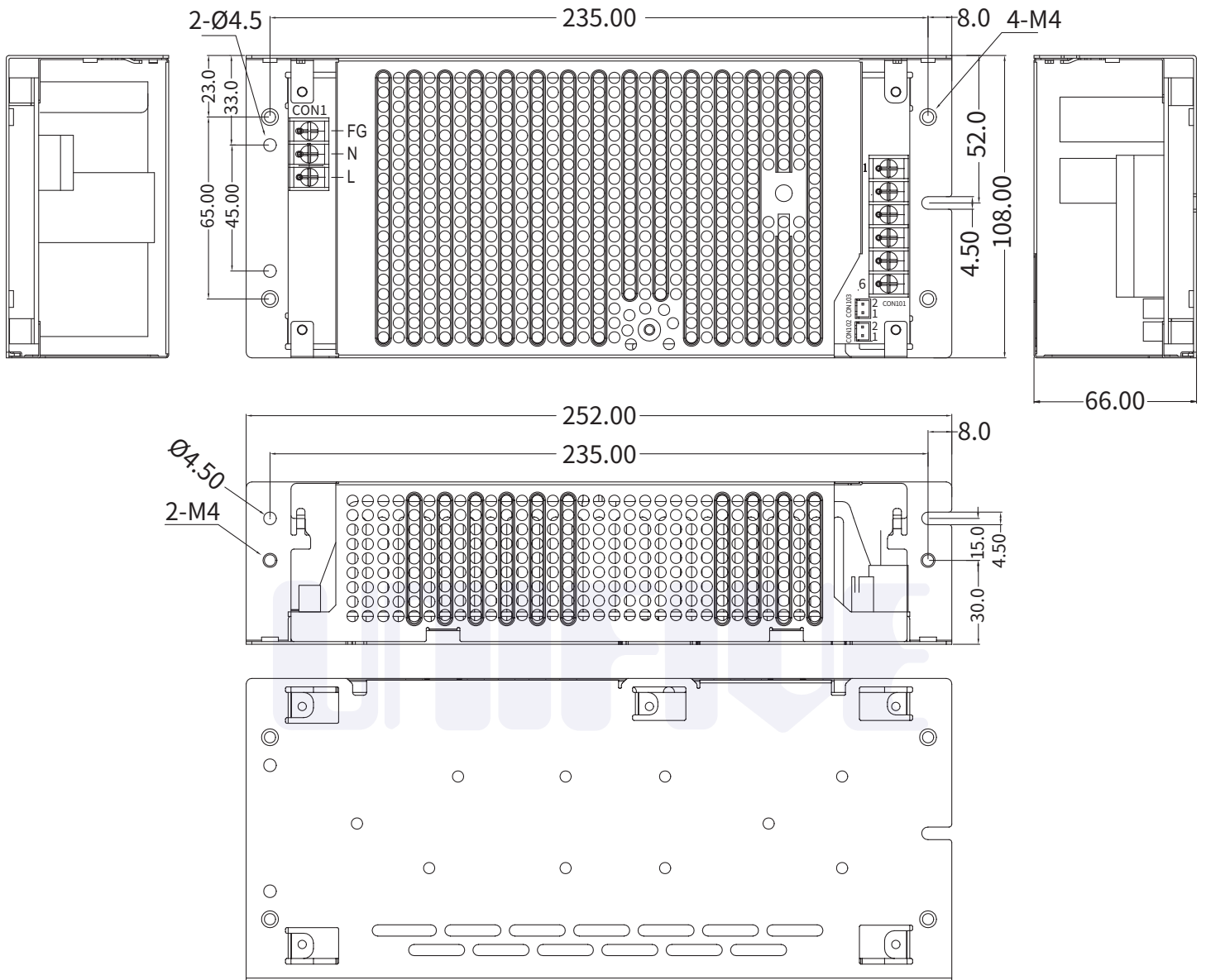

TOLERANCE: ±0.5
Unit:mm

CON1

PIN NUMBER	INPUT
1	AC(L)
2	AC(N)
3	FG
CON1 : INPUT CONNECT	

CON102

PIN NUMBER	REMOTE
1	RC(+)
2	RC(-)
CON102: REMOTE CONNECT MODEL : B2B-XH-A (THE EQUIVALENT)	

CON103

PIN NUMBER	OUTPUT
1	5V(+)
2	5V(-)
CON103: OUTPUT CONNECT MODEL : B2B-XH-A (THE EQUIVALENT)	

CON101

PIN NUMBER	OUTPUT
1-3	-V
4-6	+V
CON101: OUTPUT CONNECT	

■ Please contact our sales department for details of each model ■

Mounting methods and derating curve

Power Supply Positioning:

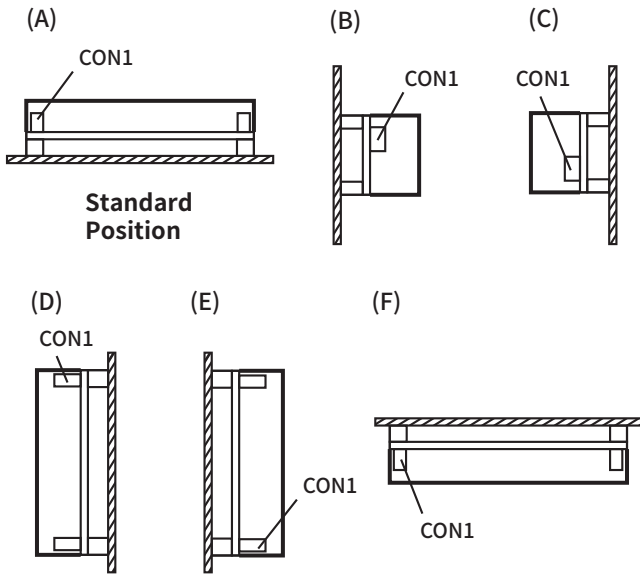

Measuring points and thermal test:

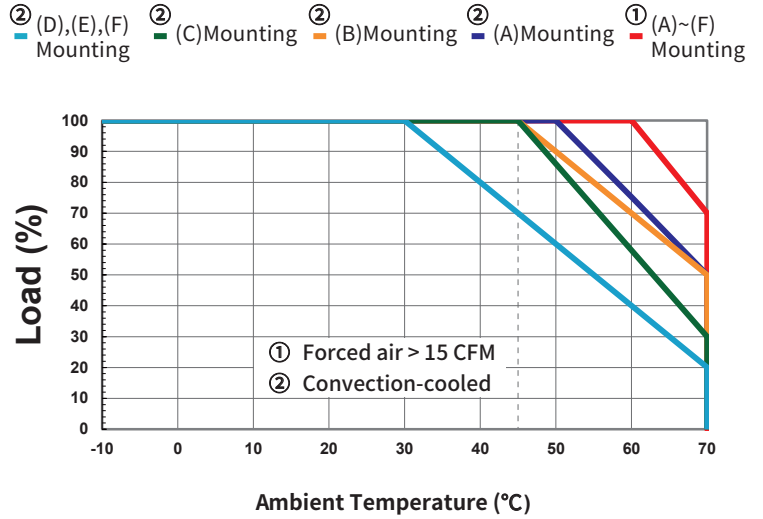

Point A and point B are indicated in mechanical spec:

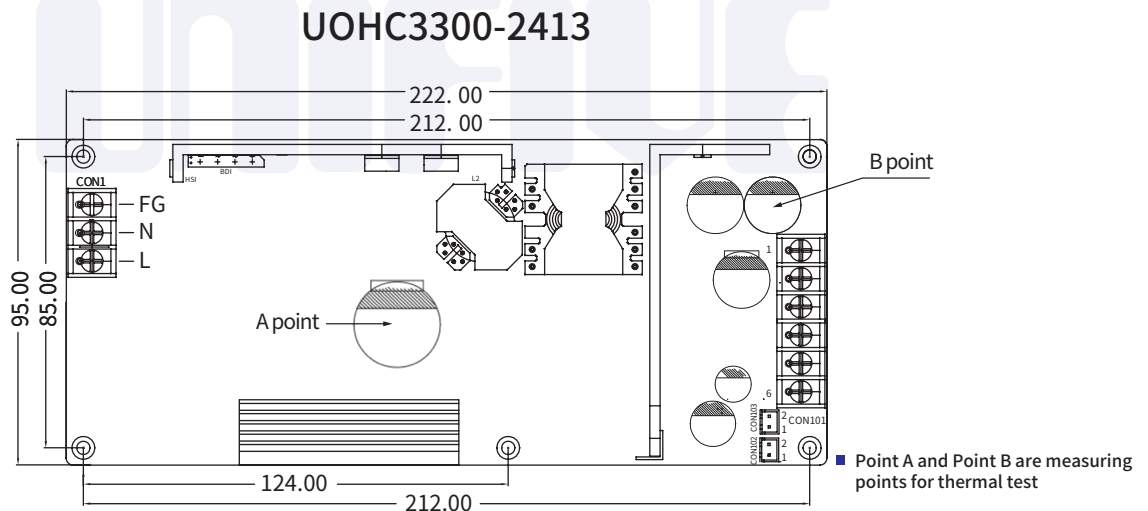

Mounting Method	Cooling Method	Load factor	Max temperature	
			Point A(°C)	Point B(°C)
A	Convection	75% < I _o ≤ 100%	79	87
		50% < I _o ≤ 75%	82	87
		0% < I _o ≤ 50%	88	90
B	Convection	75% < I _o ≤ 100%	79	82
		50% < I _o ≤ 75%	85	87
		0% < I _o ≤ 50%	88	89
C	Convection	75% < I _o ≤ 100%	80	81
		50% < I _o ≤ 75%	78	78
		0% < I _o ≤ 50%	82	81
D	Convection	75% < I _o ≤ 100%	54	60
		50% < I _o ≤ 75%	62	65
		0% < I _o ≤ 50%	69	70
E	Convection	75% < I _o ≤ 100%	53	76
		50% < I _o ≤ 75%	61	76
		0% < I _o ≤ 50%	69	79
F	Convection	75% < I _o ≤ 100%	46	46
		50% < I _o ≤ 75%	69	67
		0% < I _o ≤ 50%	75	73
A,B,C,D,E,F	Forced air	70% < I _o ≤ 100%	53	49
		0% < I _o ≤ 70%	35	33